

HC 250 BC

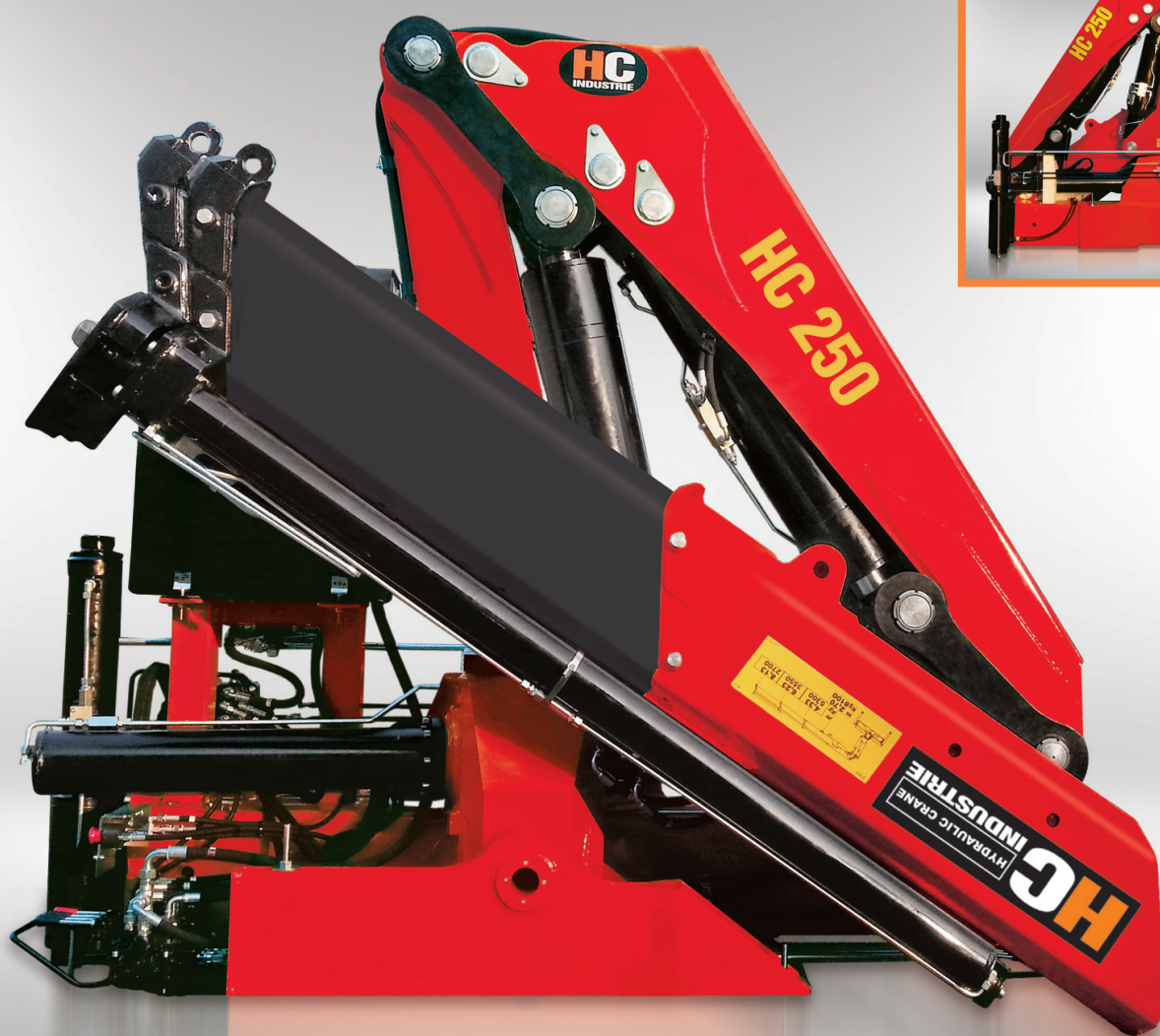

I MIGLIORI PRODOTTI DI QUALITÀ | BEST QUALITY PRODUCTS

www.hcindustrie.com

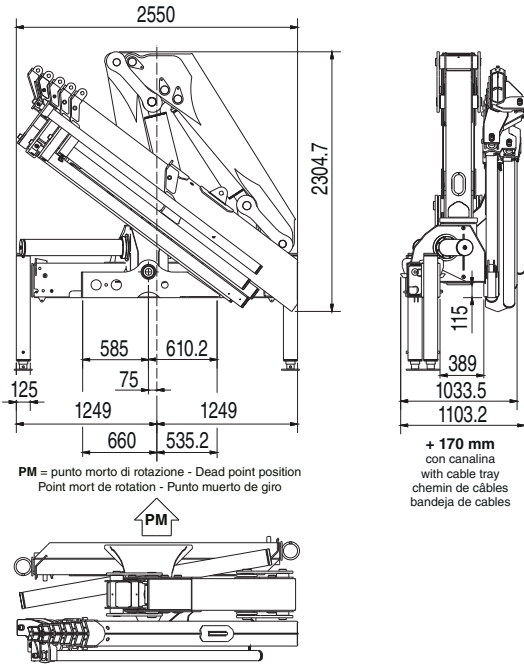

GRU STANDARD Std Crane - Grue Standard - Grua standard

Bracci stabilizzatori extra estensibili idraulici Hydraulic extra extensible outrigger booms - Bras de stabilisation hydrauliques extra-extensibles - Brazos estabilizadores hidráulicos extra extensibles	mm. 5540
Angolo di rotazione Slewing angle - Angle de rotation - Giro	400°
Tiranti di ancoraggio 42CrMo4 Tie rods for anchorage - Tirants d'ancrage - Tirantes de fijación	M30x2
Portata raccomandata Recommended oil flow - Débit recommandé - Caudal requerido	l/min. 50
Capacità del serbatoio Tank capacity - Capacité du réservoir - Capacidad del depósito de aceite	lt. 160
Pressione massima Rated pressure - Pression maxi - Presión máxima	bar 310

HC 250 BC A2

Massa della gru senza olio nel serbatoio Overhang crane without oil in the tank - Poids de la grue sans huile dans le réservoir - Peso de la grua sin aceite en el depósito	Kg. 3010
Momento di sollevamento massimo Maximum lifting moment - Moment de levage maxi - Momento de elevación máxima	tm 23,76

Sbraccio oleodinamico Maximum hydraulic reach - Déport hydraulique - Alcance hidráulico	
Orizzontale Horizontal - Horizontal - Horizontal	m. 6,23
Verticale Vertical - Vertical - Vertical	m. 9,73

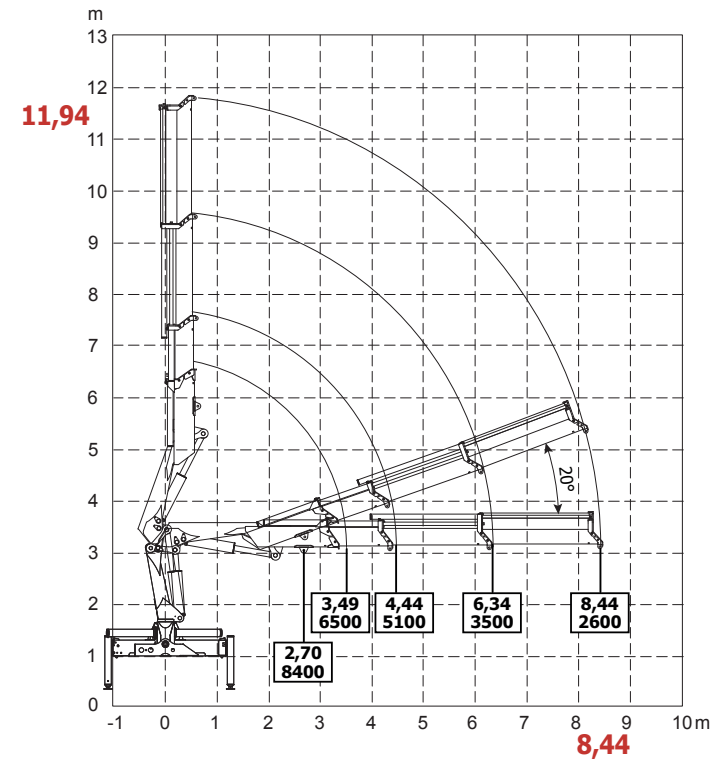
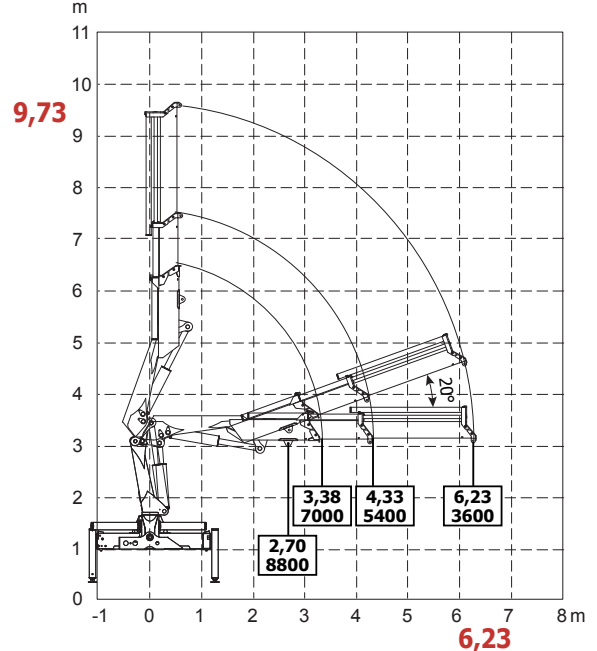

HC 250 BC A3

Massa della gru senza olio nel serbatoio Overhang crane without oil in the tank - Poids de la grue sans huile dans le réservoir - Peso de la grua sin aceite en el depósito	Kg. 3160
Momento di sollevamento massimo Maximum lifting moment - Moment de levage maxi - Momento de elevación máxima	tm 22,68

Sbraccio oleodinamico Maximum hydraulic reach - Déport hydraulique - Alcance hidráulico	
Orizzontale Horizontal - Horizontal - Horizontal	m. 8,44
Verticale Vertical - Vertical - Vertical	m. 11,94

GRU STANDARD Std Crane - Grue Standard - Grua standard

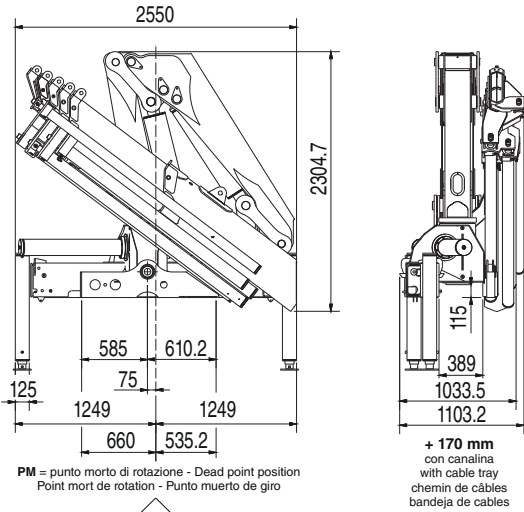

Bracci stabilizzatori extra estensibili idraulici Hydraulic extra extensible outrigger booms - Bras de stabilisation hydrauliques extra-extensibles - Brazos estabilizadores hidráulicos extra extensibles	mm. 5540
Angolo di rotazione Slewing angle - Angle de rotation - Giro	400°
Tiranti di ancoraggio 42CrMo4 Tie rods for anchorage - Tirants d'ancrage - Tirantes de fijación	M30x2
Portata raccomandata Recommended oil flow - Débit recommandé - Caudal requerido	l/min. 50
Capacità del serbatoio Tank capacity - Capacité du réservoir - Capacidad del depósito de aceite	lt. 160
Pressione massima Rated pressure - Pression maxi - Presión máxima	bar 310

HC 250 BC A4

Massa della gru senza olio nel serbatoio
Overhang crane without oil in the tank - Poids de la grue sans huile dans le réservoir - Peso de la grua sin aceite en el depósito

Kg. 3290

Momento di sollevamento massimo
Maximum lifting moment - Moment de levage maxi - Momento de elevación máxima

tm 22,14

Sbraccio oleodinamico
Maximum hydraulic reach - Déport hydraulique - Alcance hidráulico

Orizzontale Horizontal - Horizontal - Horizontal
Verticale Vertical - Vertical - Vertical

m. 10,65
m. 14,15

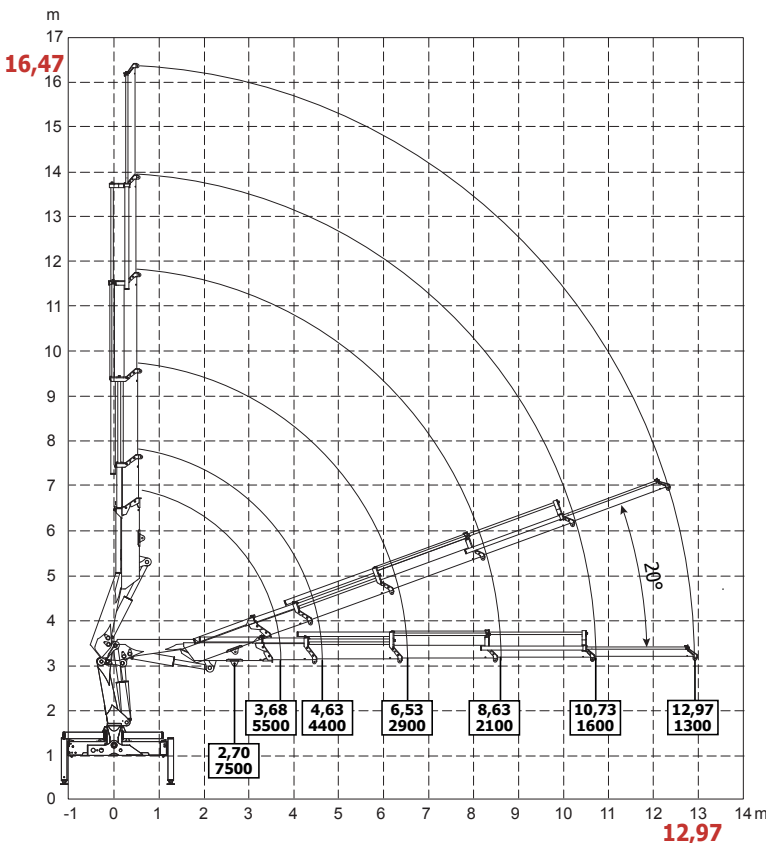
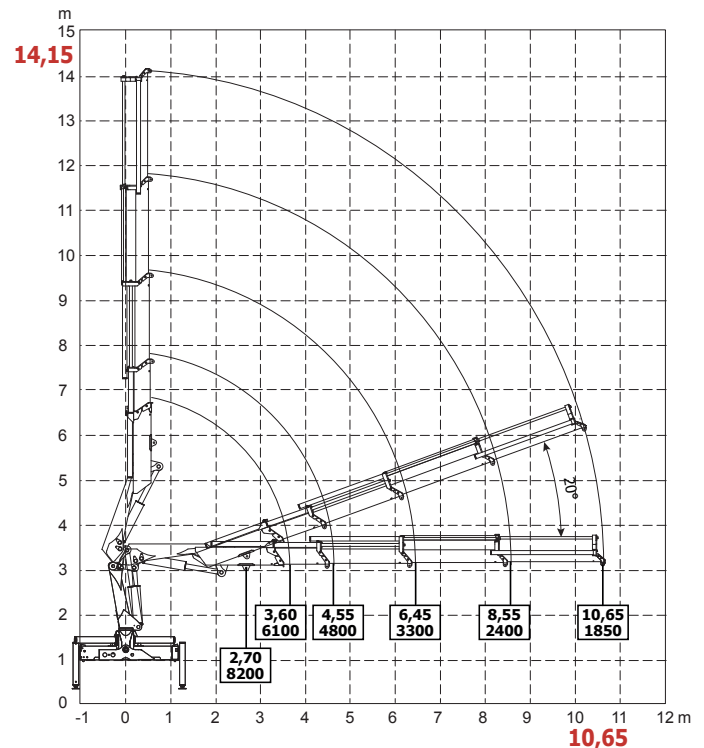

HC 250 BC A5

Massa della gru senza olio nel serbatoio
Overhang crane without oil in the tank - Poids de la grue sans huile dans le réservoir - Peso de la grua sin aceite en el depósito

Kg. 3420

Momento di sollevamento massimo
Maximum lifting moment - Moment de levage maxi - Momento de elevación máxima

tm 20,25

Sbraccio oleodinamico
Maximum hydraulic reach - Déport hydraulique - Alcance hidráulico

Orizzontale Horizontal - Horizontal - Horizontal
Verticale Vertical - Vertical - Vertical

m. 12,97
m. 16,47

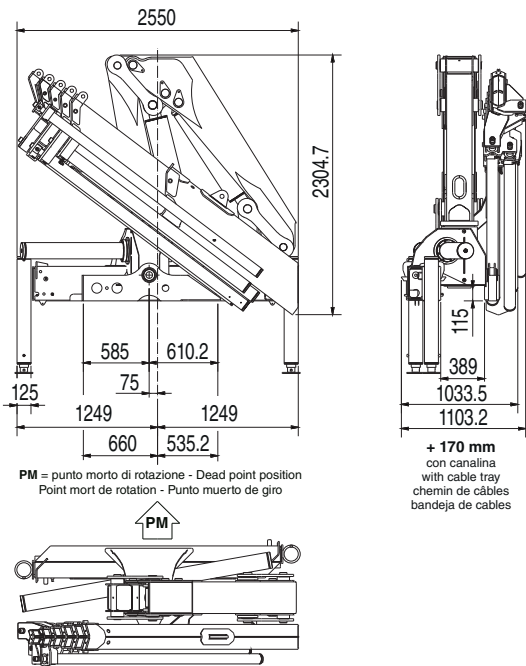

GRU STANDARD Std Crane - Grue Standard - Grua standard

Bracci stabilizzatori extra estensibili idraulici
 Hydraulic extra extensible outrigger booms - Bras de stabilisation hydrauliques extra-extensibles - Brazos estabilizadores hidráulicos extra extensibles **mm. 5540**

Angolo di rotazione
 Slewing angle - Angle de rotation - Giro **400°**

Tiranti di ancoraggio 42CrMo4
 Tie rods for anchorage - Tirants d'ancrage - Tirantes de fijación **M30x2**

Portata raccomandata
 Recommended oil flow - Débit recommandé - Caudal requerido **l/min. 50**

Capacità del serbatoio
 Tank capacity - Capacité du réservoir - Capacidad del depósito de aceite **lt. 160**

Pressione massima
 Rated pressure - Pression maxi - Presión máxima **bar 310**

HC 250 BC A6

Massa della gru senza olio nel serbatoio
 Overhang crane without oil in the tank - Poids de la grue sans huile dans le réservoir - Peso de la grua sin aceite en el depósito **Kg. 3670**

Momento di sollevamento massimo
 Maximum lifting moment - Moment de levage maxi - Momento de elevación máxima **tm 19,71**

Sbraccio oleodinamico
 Maximum hydraulic reach - Déport hydraulique - Alcance hidráulico **m. 15,31**

Orizzontale Horizontal - Horizontal - Horizontal **m. 18,81**
Verticale Vertical - Vertical - Vertical **m. 18,81**

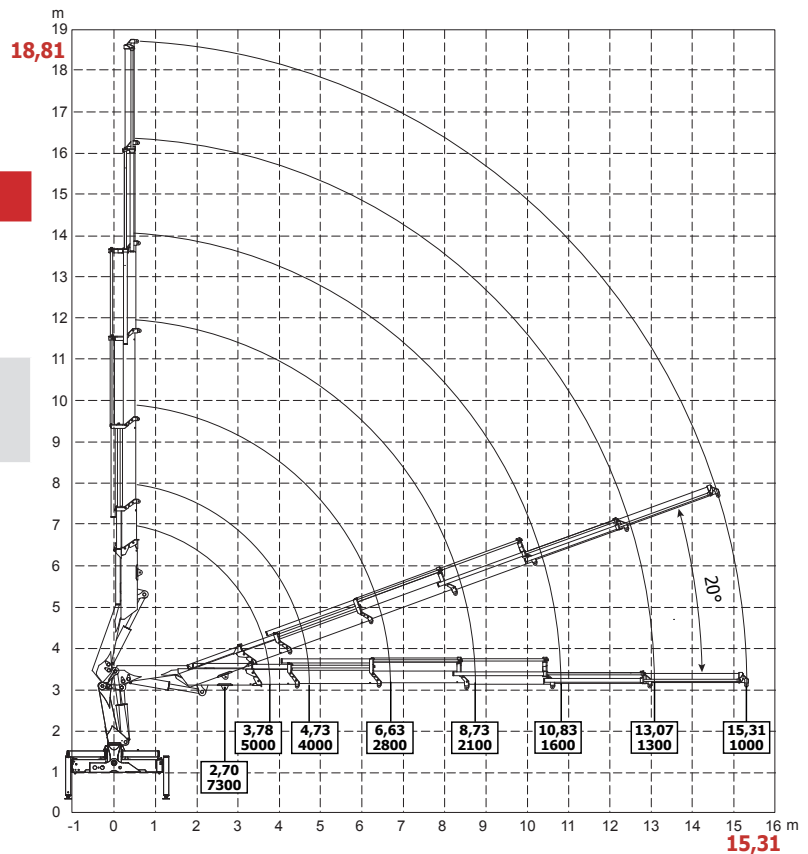

TUTTI I DATI TECNICI POSSONO ESSERE CAMBIATI SENZA PREAVVISO - ALL TECHNICAL DATA CAN BE CHANGED WITHOUT NOTICE
 TOUS LES DONNEES TECHNIQUES PEUVENT ETRE MODIFIEES SANS PREAVIS - TODOS LOS DATOS TECNICOS PUEDEN SER CAMBIADOS SIN AVISO

HC INDUSTRIE S.R.L.
 Via Luciano Romagnoli, 1
 42023 Cadelbosco di Sopra Reggio Emilia, Z.I. La Madonnina (RE)
 Phone +39.0522.911729 - Fax +39.0522.404040
 Email: commerciale@hcindustrie.com - Website: www.hcindustrie.com